

AMSTRAD 900,901
MUSTANG 1000,2000,3000
HARVARD 402, 407, H646
SPINNEYTRONIC CB199
FIDELITY 2001
NATO 40FM
TRANSCOM

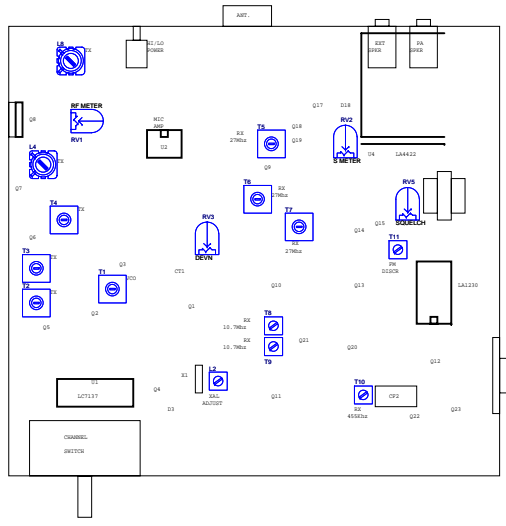

THIS DIAGRAM IS AN ATTEMPT TO MAKE THE CIRCUIT EASIER TO FOLLOW THAN THE ORIGINAL. OF NECESSITY THIS MEANS THAT THE FRONT AND REAR PANEL COMPONENTS ARE NOT DRAWN TOGETHER (AS ON THE ORIGINAL) BUT ARE DRAWN WHERE REQUIRED - I'M SURE YOU CAN FIGURE OUT WHERE THEY ARE :-) THE POWER SUPPLY SECTION ON THE ORIGINAL WAS DREADFUL, AND HOPEFULLY IS NOW DRAWN SO THAT IT IS EASILY UNDERSTANDABLE. ANY SUGGESTIONS FOR IMPROVEMENTS OR CORRECTIONS OF ERRORS SHOULD BE ADDRESSED TO ME AT THE EMAIL ADDRESS GIVEN IN THE TITLE BLOCK AT THE BOTTOM RIGHT HAND CORNER.

Copyright:
This diagram is my copyright. You are welcome to use the diagram for your own personal use and to use it to repair radios commercially, however you are not permitted to publish the diagram by any means (electronically, hardcopy or otherwise) without paying royalties to me (Colin Hinson). The website <http://www.cbtricks.com> has my permission to host this pdf document.

- NOTES:**
- *1 ON EARLY CHASSIS, 47K IS IN SERIES WITH RV5 (SQUELCH PRESET). THIS SHOULD BE SHORTED OUT TO GET BETTER SQUELCH ACTION
 - *2 ON CHASSIS WITH METERS (MUSTANGS, TRANSCOM etc), D13 IS FITTED IN PLACE OF THE WIRE LINK NEXT TO T11. THESE RADIOS REALLY NEED AT LEAST ONE MORE DIODE IN SERIES IN ORDER TO REDUCE THE READING ON THE METER TO ZERO FOR NO SIGNAL INPUT.
 - C134 IS NOT MOUNTED ON ALL BOARDS (IT IS NOW TO R01 (30K, 6V LINE).
 - Q13 IS NOT FITTED (UNTESTED FOLLOWERS)
 - Q14 IS NOT FITTED
 - Q15 IS NOT FITTED
 - Q16 IS NOT FITTED
 - Q17 IS NOT FITTED
 - Q18 IS NOT FITTED
 - Q19 IS NOT FITTED
 - Q20 IS NOT FITTED
 - Q21 IS NOT FITTED
 - Q22 IS NOT FITTED
 - Q23 IS NOT FITTED
 - Q24 IS NOT FITTED
 - Q25 IS NOT FITTED
 - Q26 IS NOT FITTED
 - Q27 IS NOT FITTED
 - Q28 IS NOT FITTED
 - Q29 IS NOT FITTED
 - Q30 IS NOT FITTED
 - Q31 IS NOT FITTED
 - Q32 IS NOT FITTED
 - Q33 IS NOT FITTED
 - Q34 IS NOT FITTED
 - Q35 IS NOT FITTED
 - Q36 IS NOT FITTED
 - Q37 IS NOT FITTED
 - Q38 IS NOT FITTED
 - Q39 IS NOT FITTED
 - Q40 IS NOT FITTED
 - Q41 IS NOT FITTED
 - Q42 IS NOT FITTED
 - Q43 IS NOT FITTED
 - Q44 IS NOT FITTED
 - Q45 IS NOT FITTED
 - Q46 IS NOT FITTED
 - Q47 IS NOT FITTED
 - Q48 IS NOT FITTED
 - Q49 IS NOT FITTED
 - Q50 IS NOT FITTED
 - Q51 IS NOT FITTED
 - Q52 IS NOT FITTED
 - Q53 IS NOT FITTED
 - Q54 IS NOT FITTED
 - Q55 IS NOT FITTED
 - Q56 IS NOT FITTED
 - Q57 IS NOT FITTED
 - Q58 IS NOT FITTED
 - Q59 IS NOT FITTED
 - Q60 IS NOT FITTED
 - Q61 IS NOT FITTED
 - Q62 IS NOT FITTED
 - Q63 IS NOT FITTED
 - Q64 IS NOT FITTED
 - Q65 IS NOT FITTED
 - Q66 IS NOT FITTED
 - Q67 IS NOT FITTED
 - Q68 IS NOT FITTED
 - Q69 IS NOT FITTED
 - Q70 IS NOT FITTED
 - Q71 IS NOT FITTED
 - Q72 IS NOT FITTED
 - Q73 IS NOT FITTED
 - Q74 IS NOT FITTED
 - Q75 IS NOT FITTED
 - Q76 IS NOT FITTED
 - Q77 IS NOT FITTED
 - Q78 IS NOT FITTED
 - Q79 IS NOT FITTED
 - Q80 IS NOT FITTED
 - Q81 IS NOT FITTED
 - Q82 IS NOT FITTED
 - Q83 IS NOT FITTED
 - Q84 IS NOT FITTED
 - Q85 IS NOT FITTED
 - Q86 IS NOT FITTED
 - Q87 IS NOT FITTED
 - Q88 IS NOT FITTED
 - Q89 IS NOT FITTED
 - Q90 IS NOT FITTED
 - Q91 IS NOT FITTED
 - Q92 IS NOT FITTED
 - Q93 IS NOT FITTED
 - Q94 IS NOT FITTED
 - Q95 IS NOT FITTED
 - Q96 IS NOT FITTED
 - Q97 IS NOT FITTED
 - Q98 IS NOT FITTED
 - Q99 IS NOT FITTED
 - Q100 IS NOT FITTED

EVIL FAULT:
TX AND RX LIGHTS ON TOGETHER: Q22 LEAKY

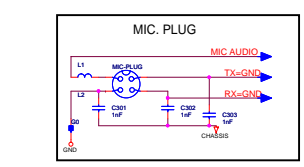
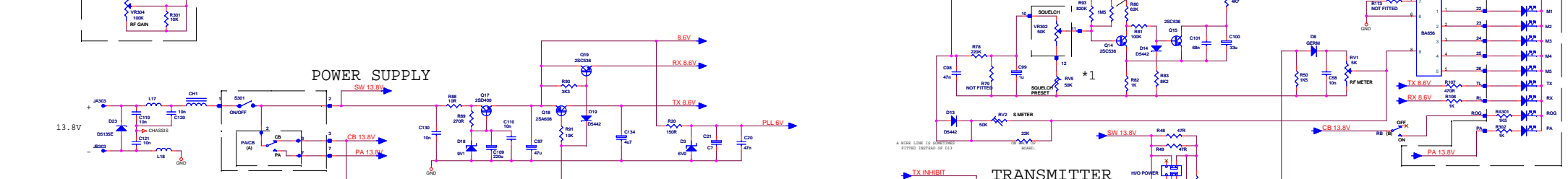
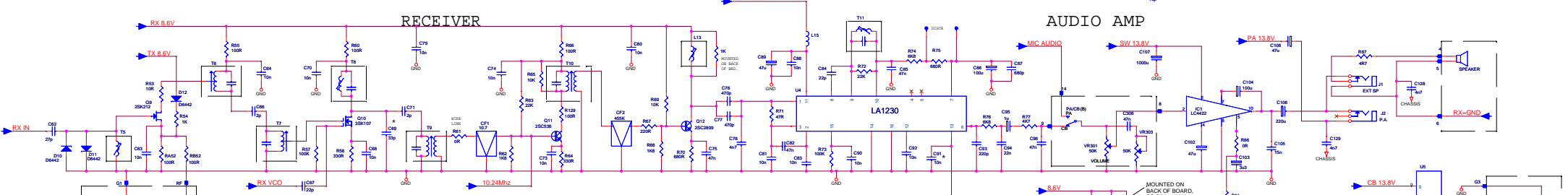
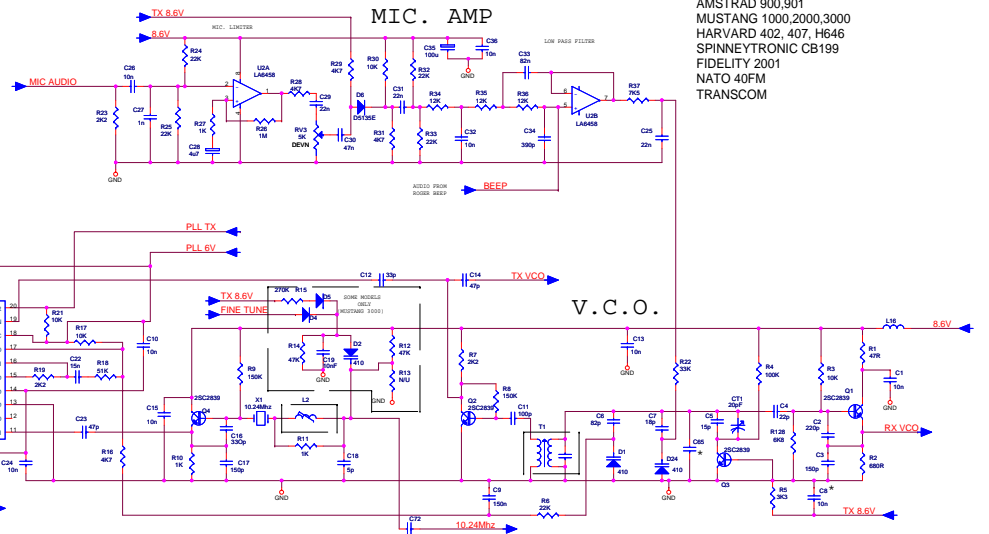

AMSTRAD

COLIN HINSON (G3LNU)
EMAIL: CHinson@Bham.ac.uk
WEB: www.cbtricks.com
D AMSTRAD.SCH
Date: Monday, February 27, 2011 Page: 6 of 9