

This Manual is provided by
CBTricks.com

Someone who wanted to help you repair your equipment put together this information.

Courier Renegade 23 Channel Owner's Manual
If you would like to help us put more manuals online support us.

If you would like to help with this project let us know.

Supporters of CBTricks.com paid for the hosting so you would have this file.

CBTricks.com is a non-commercial personal website was created to help promote the exchange of service, modification, technically oriented information, and historical information aimed at the Citizens Band, GMRS (CB "A" Band), MURS, Amateur Radios and RF Amps.

CBTricks.com is not sponsored by or connected to any Retailer, Radio, Antenna Manufacturer or Amp Manufacturer, or affiliated with any site links shown in the links database. The use of product or company names on my web site is not endorsement of that product or company.

If your company would like to provide technical information to be featured on this site I will put up on the site as long as I can do it in a non-commercial way.

The site is supported with donation from users, friends and selling of the Galaxy Service Manual CD to cover some of the costs of having this website on the Internet instead of relying on banner ads, pop-up ads, commercial links, etc. Thus I do not accept advertising banners or pop-up/pop-under advertising or other marketing/sales links or gimmicks on my website.

ALL the money from donations is used for CBTricks.com I didn't do all the work to make money (I have a day job). This work was not done for someone else to make money also, for example the ebay CD sellers.

All Trademarks, Logos, and Brand Names are the property of their respective owners.

This information is not provided by, or affiliated in any way with any radio or antenna Manufacturers.

Thank you for any support you can give.



RENEGADE

**CITIZENS BAND TRANSCEIVER
SOLID STATE · DC OPERATION**



FCC TYPE ACCEPTED

INSTRUCTION MANUAL

NOTICE

FCC Rules and Regulations, Part 95, requires that only those persons possessing a valid First or Second Class Radio Telephone Operator's license are permitted to make repairs or adjustments in the transmitter section of any Citizens Band Transceiver.

CERTIFICATION

FANON/COURIER Corporation, Pasadena, California, certifies that this Citizens Band Transceiver meets FCC Rules and Regulations, Part 95, regarding frequency tolerance, stability, power input, modulation, and spurious suppression.

This certification is void if crystals other than those recommended by the manufacturer are installed or if any modification is made to the transmitter circuits, not specified by FANON/COURIER Corporation, or by any personnel not holding the proper FCC license.

STATION LICENSE REQUIREMENTS

Before placing the transmitter on the air, a valid permanent Class D Citizens Band Radio Station License or a Temporary Permit must be obtained, as follows:

1. Read and understand the FCC Rules and Regulations, Volume VI, Part 95, provisions dealing with permissible communications for Class D Citizens Band Radio Stations.
2. Complete FCC Form 505, Application for Permanent Class D Station License and mail to Federal Communications Commission, Box 1010, Gettysburg, Pa. 17325.
3. Complete FCC Form 555-B, DO NOT MAIL the form to the FCC. The Temporary Permit is valid for 60 days from the date of application for a Permanent Station License.

A copy of Part 95 of the FCC Rules and Regulations may be obtained from the Superintendent of Documents, Government Printing Office, Washington, D. C. 20402.

License applications, FCC Form 505, may be obtained from the Federal Communications Commission, Washington, D. C. 20554 or from the nearest FCC Field Office listed below.

FCC FIELD OFFICES

Mobile, AL 36602	Boston, MA 02109
Anchorage, AK 99501	Detroit, MI 48226
Los Angeles, CA 90012	St. Paul, MN 55101
San Diego, CA 92101	Kansas City, MO 64106
San Francisco, CA 94111	Buffalo, NY 14203
San Pedro, CA 90731	New York, NY 10014
Denver, CO 80202	Portland, OR 97204
Miami, FL 33130	Philadelphia, PA 19106
Tampa, FL 33602	San Juan, PR 00903
Atlanta, GA 30303	Beaumont, TX 77701
Savannah, GA 31402	Dallas, TX 75202
Honolulu, HI 96808	Houston, TX 77002
Chicago, IL 60604	Norfolk, VA 23510
New Orleans, LA 70130	Seattle, WA 98104
Baltimore, MD 21202	

GENERAL DESCRIPTION

Your RENEGADE is designed to receive AM signals in the 26.965 to 27.255 MHz Citizens Band. The circuit is a highly sensitive and selective dual conversion superheterodyne type. Full 23 channels, crystal controlled operation is provided by a frequency-synthesized circuit consisting of 12 crystals.

The receiver section includes an "S" Meter for reading signal strength; an adjustable Squelch Control to eliminate background noise when no signal is being received; an Automatic Noise Limiter to suppress atmospheric and man-made interference, enhancing the reception of distant and low power stations.

The frequency synthesizer used in the receiver section is also common to the transmitter section. The transmitter is capable of producing full 5 watts, at 100% modulation, to the final RF stage.

NOMINAL SPECIFICATIONS

General

- * Transistor - 20
- * Diode - 14
- * Self-contained speaker-3-1/4" round type-8 ohm voice coil
- * Detachable Dynamic Microphone with press-to-talk switch - 600 ohm
- * Illuminated Channel Indicator and "S"/RF power meter
- * 50 ohm external antenna impedance
- * Operated from 13.8V DC supply negative or positive ground
- * 23 channel selector switch
- * Volume control with power ON/OFF switch
- * External Speaker and P.A. Jacks
- * Noise Limiter Switch
- * Coaxial type antenna connector
- * Under dash mounting bracket
- * Mechanical Filter - 1
- * Squelch control

RECEIVER SECTION

. Frequency Range	26.965 to 27.255 MHz
. Sensitivity	0.25 μ V/m for 10 db S+N/N ratio at 30% Modulation at 1 kHz.
. Selectivity	60db down at \pm 3 kHz; 50db down at \pm 10 kHz.
. Adjacent Channel Rejection	Better than 50 db
. Audio Distortion 1000 Hz	Less than 7%
. Spurious Response	50 db
. Squelch Sensitivity	.5 μ V
. Squelch Stop Sensitivity	630 μ V
. Noise Limiter	Series gate
. Audio output at 8 ohms	2.5W (10%)
. Intermediate Frequency	1st IF: 11.275 MHz, 2nd IF: 455 kHz
. Hum and Noise	50 db down, nominal

TRANSMITTER SECTION

. Frequency Range	26.965 to 27.255 MHz
. Power Input at 13.8V DC	5W
. Power Output at 13.8V DC	3W, Nominal
. Modulation (5mW at Mic)	100%
. Emission Class D operation	6A3
. Frequency Tolerance	\pm .005%
. Antenna Matching	50 ohms (Nominal)
. Switching	Electronic
. Modulation Distortion	Less than 7% at 85% modulation at 1000 Hz.
. Harmonic Suppression	Better than 50 db down
. Modulation Limiter	Yields high average voice levels.

INSTALLATION

MOBILE STATION INSTALLATION

Use the mounting bracket supplied as a template to locate the mounting holes for mounting the bracket. Secure the bracket under the dash at a position easily reached by the operator. The transceiver may be tilted in the mounting bracket for the best view of the front panel and for operation of the controls.

CAUTION

The transceiver has a polarity protection diode in the DC power circuit. If the power source polarity is reversed, the fuse will blow. CHECK CAREFULLY THE POLARITY CONNECTIONS BEFORE YOU TURN ON THE POWER SWITCH.

UNDER NO CIRCUMSTANCES SHOULD A LARGER FUSE BE USED THAN THE ONE ORIGINALLY SUPPLIED (1.5 ampere) AND NEVER BYPASS THE FUSE WITH A JUMPER WIRE. IN EITHER OF THESE INSTANCES SEVERE DAMAGE TO YOUR TRANSCEIVER CAN OCCUR AND YOUR WARRANTY IS VOIDED.

NEGATIVE GROUND CONNECTIONS (Figure 2)

The unit is supplied ready for connections to a NEGATIVE grounded power source. Connect the RED lead to the POSITIVE terminal of the battery or accessory connection on an ignition switch. Connect the BLACK lead to the frame of the vehicle or at the COMMON ground terminal used by other accessories. Be sure to connect the antenna connector to the rear connector of the transceiver and remember that the unit will not operate until the microphone is connected.

CONNECTIONS FOR POSITIVE GROUNDED VEHICLES (Figure 2)

In positive grounded power supplies the POSITIVE terminal of the battery or other power source is connected to the ignition switch accessory connection or directly to the NEGATIVE terminal on the battery or other power source. The other connections are the same as for a negative grounded system.

MICROPHONE

The package containing the five self-tapping screws also contains a microphone hanging bracket. It is recommended that a location for this hanger be chosen that will permit the microphone cable to be free from obstructing other controls. For convenience, it is desirable to locate the hanger somewhere on the dashboard within easy reach of the operator so that the microphone may be grasped without the operator having to take his eyes off the road. When the approximate location has been chosen, use the hanger as a template and center punch the centers for two #30 (.120 DIA) holes. Try to avoid locations where the microphone cord is likely to catch on objects. The inner spring should be adjusted with long nose pliers for proper holding tension. The microphone should be placed into the microphone hanger when not in use to avoid being damaged.

BASE STATION INSTALLATION

Your transceiver may also be used as a base station installation through the use of a 13.8V DC external power supply. Locate the transceiver near the antenna lead-in and a 117VAC, 60 Hz power outlet. Mount the unit under the edge of a shelf or table with the mounting bracket placed on the speaker side of the cabinet. Observe carefully the polarity of the power leads when making connections to the power supply (the red lead is positive (+) and the black lead is negative (-)). Your station license must be posted at the transmitter location and the station should not be operated by unauthorized persons. When not in use, be sure to turn the transceiver power switch OFF. If the unit will not be used for a long period of time, the external power supply cord should be removed from the power outlet.

ANTENNA INSTALLATION

Your transceiver is designed to operate with any good quality Citizens Band base or mobile antenna. The type of antenna you should use depends largely upon how and where the antenna is to be mounted and the radiation pattern desired or required. All FANON/COURIER dealers are qualified to assist you in the selection of the proper type to meet your needs.

An antenna matching circuit is featured which, under most conditions, requires no adjusting if the antenna load impedance is between 35 and 100 ohms. In most cases the antenna cable supplied with Citizens Band antenna is of the proper length for connecting directly to the transceiver antenna connector on the back panel.

If it is necessary to change the cable, to increase or decrease the length, type RG 58/U is recommended for lengths under 50 feet.

To check the "standing wave" between the antenna and the transceiver, use a COURIER Port-A-Lab 500 Voltage Standing Wave Ratio Meter, or an equivalent instrument. Follow the instructions given with the instrument.

For best results, a properly matched antenna with a standing wave ratio of 1.5 to 1 or less is recommended.

The length of the transmission cable is very important, as the length will vary according to the transmission "velocity factor" of the cable. The length of cables with a velocity factor of 0.66 (regular type cable) should be in odd multiples of 6 feet for a frequency of 27 MHz. Cables with a velocity factor of 0.82 (foam type dielectric) should be in odd multiples of 7.5 feet for 27 MHz installations.

The formula for determining the length in feet of the cable you may use, is as follows:

$$\text{Cable length} = \frac{246 V}{f}$$

Where V = Transmission Velocity Factor of the cable

f = Frequency in Megahertz

FUNCTION OF CONTROLS

VOLUME CONTROL - POWER ON/OFF SWITCH

When this control is turned fully counterclockwise, the power switch is in the OFF position. Turning the control clockwise turns the power ON and controls the volume level.

CHANNEL SELECTOR

The channel selector has 23 operating positions and one blank position. The transmitter and receiver frequencies are set simultaneously upon selection of a desired channel.

SQUELCH CONTROL

This control will silence background noise when a signal is not being received. Correct adjustment of the control is as follows:

Adjust the squelch control fully counterclockwise and adjust the volume control approximately 1/2 of its rotation and select a channel on which no signal is being received. Turn the squelch control clockwise just to the point where the background noise stops. Upon receipt of a signal, the squelch will open and the station will be heard. (If adjusted too far past this point, weak signals may not be heard).

"S"/RF METER

Meter indicates relative signal strength of incoming signals from 1 through 9. A reading of 1 indicates a weak or distant station and a reading 9 would indicate a local or a higher power station. The RF power scale indicates the relative RF power in watts being transmitted by your transmitter.

NL (NOISE LIMITER) SWITCH

Set this switch to OFF for normal operation. When there is large electrical interference, set the switch to NL.

CB/PA SWITCH

Set this switch to the CB position for Citizens Band operation and to the PA position when using the transceiver as a public address amplifier. A speaker must be plugged into the PA SPK jack on the rear of the chassis. The transceiver volume control will not control the volume level of the PA speaker. Prepare an 8 ohm horn or speaker with an insulated cable, FANON/COURIER Model 2W, or equivalent, a miniature phone plug, (H. H. Smith #480) or equivalent and a 5K ohm volume control. Plug into the PA SPK jack. (See diagram).

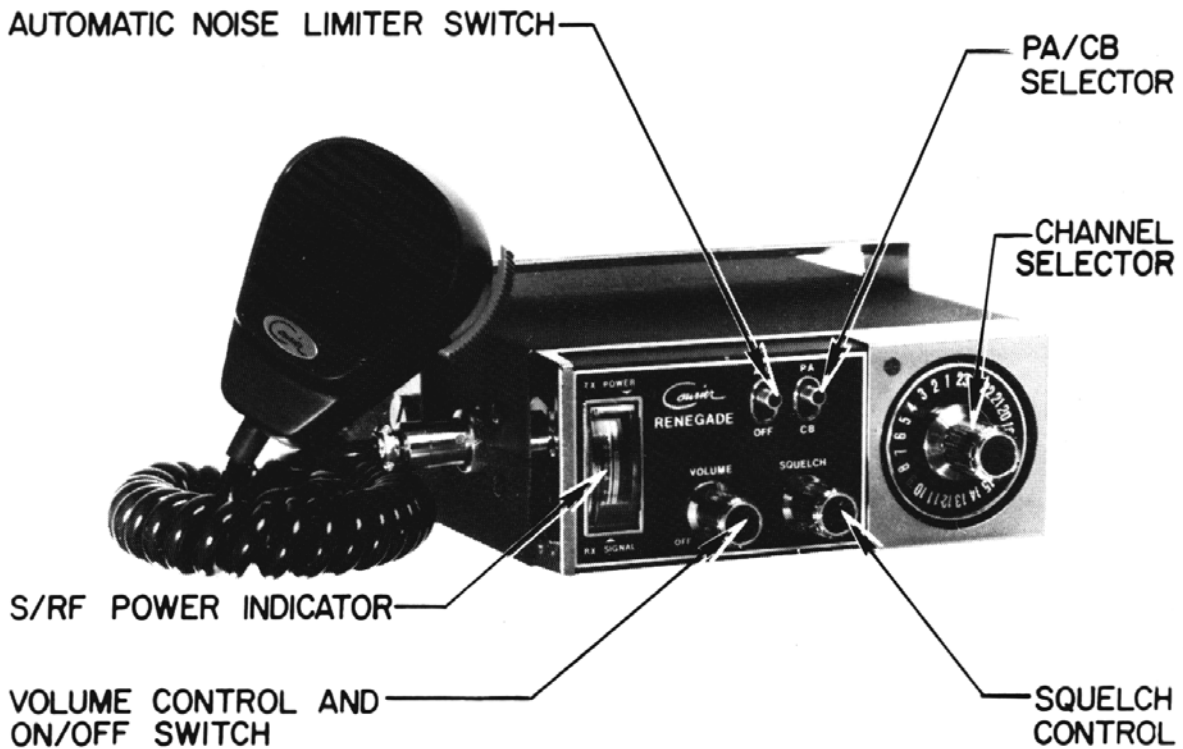

FRONT VIEW

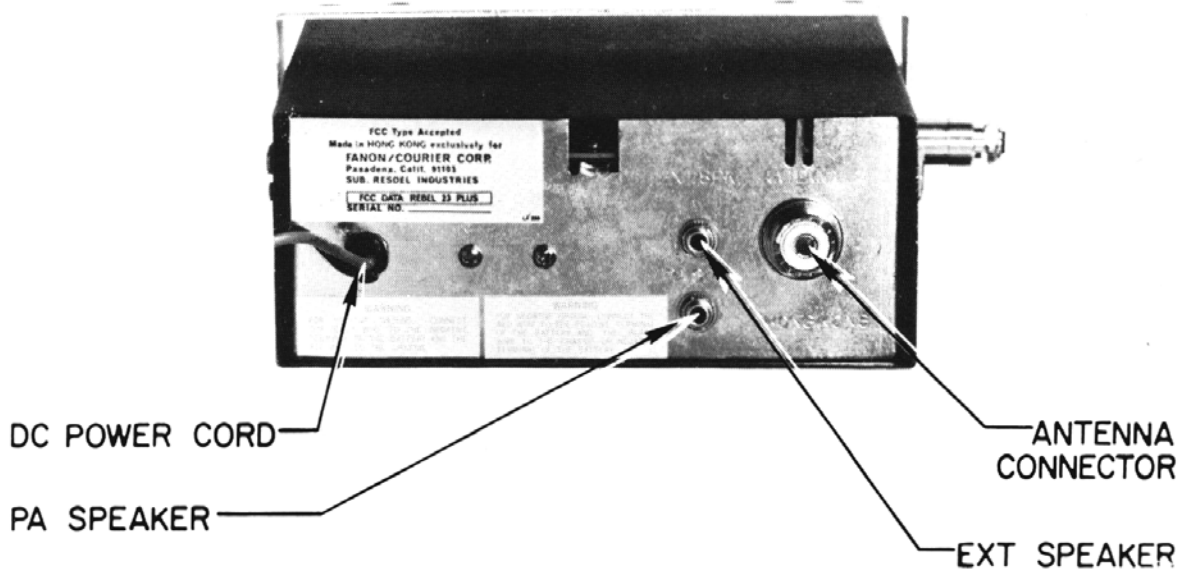

REAR VIEW

FIGURE 1, CONTROLS, INDICATORS AND CONNECTORS

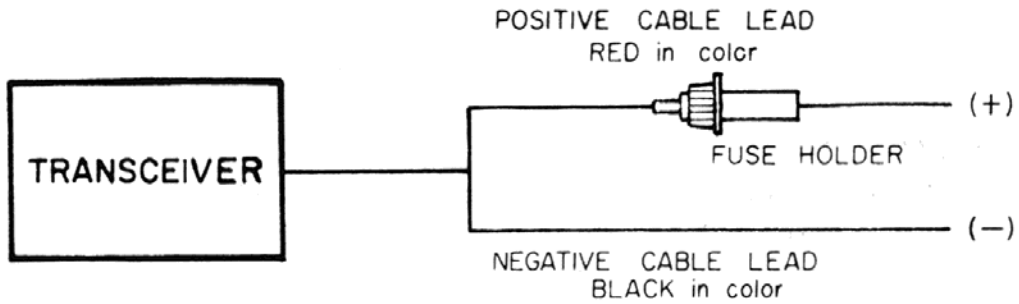
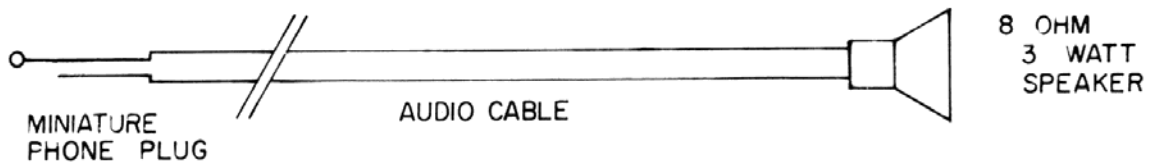
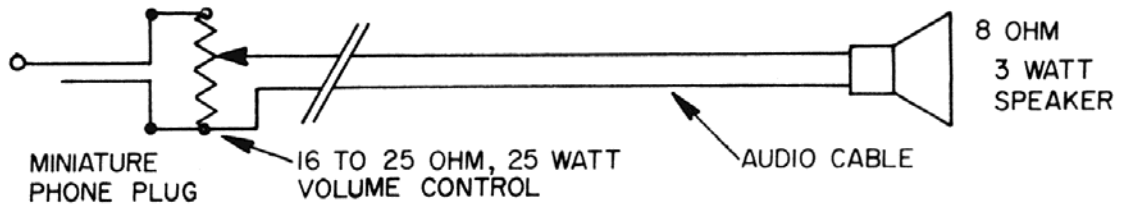

FIGURE 2, POWER CABLE LEAD IDENTIFICATION DIAGRAM



EXTERNAL SPEAKER JACK



P. A. SPEAKER CABLE CONNECTIONS

FIGURE 3, EXTERNAL SPEAKER CABLE CONNECTIONS

CAUTION: SPEAKER WIRE MUST NOT BE GROUNDED, OR CONNECTED IN ANY WAY TO THE TRANSCEIVER CHASSIS OR POWER SOURCE, SUCH AS THE VEHICLE FRAME.

Set the CB/PA switch to PA and press the microphone switch. Adjust the added volume control for the proper audio level at the PA speaker or horn. When the CB/PA switch is in the PA position, all other functions of the transceiver are turned off.

EXTERNAL SPEAKER-JACK

Prepare an 8 or 16 ohm speaker as shown in the diagram (without the volume control) and plug into the EXT-SPK jack on the rear panel. The internal speaker will be cut out.

CAUTION: BEFORE INSERTING THE EXT SPK PLUG INTO THE JACK ON THE REAR PANEL, THE POWER SWITCH MUST BE IN THE OFF POSITION. ALSO, THE SPEAKER LEADS MUST NOT BE CONNECTED TO THE VEHICLE CHASSIS OR TO THE TRANSCEIVER CHASSIS, AS SHORTING OF THE SPEAKER LEADS TO THE VEHICLE CHASSIS WILL BURN OUT THE FUSE AND MAY CAUSE DAMAGE TO THE SPEAKER OR TRANSCEIVER.